

# Model Order Reduction of Nonlinear Circuits

Andreas Steinbrecher

**Abstract**—In this talk we develop a model order reduction for the model equations of nonlinear circuits with a small number of nonlinear elements. The presented model reduction technique is based on the decoupling of the linear and nonlinear subcircuits of the electrical circuit in a suitable way. Afterwards, a model reduction of the remained linear part will be performed using passivity-preserving balanced truncation followed by an adequate recoupling of the unchanged nonlinear subcircuit and the reduced linear subcircuit to obtain a nonlinear reduced-order model. The efficiency and applicability of the proposed model reduction approach is demonstrated on a numerical examples.

## I. INTRODUCTION

The efficient and robust numerical simulation of electrical circuits plays a major role in computer aided design of electrical devices. While the structural size of the electrical devices is decreasing, the complexity of the electrical circuits is increasing. This usually leads to a system of model equations in form of differential-algebraic equations (DAE) consisting up to millions or even more unknowns. Simulation of such large models is mostly impossible or, at least, unacceptably time and storage consuming. Model order reduction presents a way out of this dilemma. A general idea of model order reduction is to replace a large-scale system by a much smaller model which approximates the input-output relation of the large-scale system within a required accuracy. While a large variety of model reduction techniques such as PRIMA [4], SPRIM [1], [2], PABTEC [6], exists for linear networks, model reduction of nonlinear circuits is only in its infancy [5], [8], [9], [10], [12].

In [3], model reduction for nonlinear circuits based on decoupling of linear and nonlinear elements for a special class of RLC circuits with only nonlinear resistors has been considered and global error bounds have been presented. In this paper, we extend these results to more general circuits that may contain other nonlinear elements like nonlinear capacitors, inductors or transistors. We restrict ourself to circuits with a small number of nonlinear elements. In this case the extracted linear subcircuits have a small number of inputs and can be reduced by any linear model reduction method. For this purpose, we will use the passivity-preserving balanced truncation method for electrical circuits (PABTEC) proposed first in [6].

Extracting the linear subsystems from a DAE system, unexpected effects, e.g., change of the index, may occur that results then in poor approximation, numerical difficulties and even failure of simulation tools. In this paper, we develop

a topology-based decoupling technique that maintains in particular the index of the DAE system.

The paper is organized as follows. In Section II, we introduce the model equations in form of a nonlinear DAE system using the MNA. In Section III, we present a model reduction technique which is based on the decoupling of subcircuits followed by a model reduction of these subcircuits, and afterwards followed by an adequate recoupling of the reduced subcircuit to obtain a nonlinear reduced-order model. Furthermore, in Section IV, we illustrate the efficiency and applicability of the proposed model reduction approach on a numerical example.

## II. CIRCUIT EQUATIONS

A commonly used tool for modeling electrical circuits is the Modified Nodal Analysis (MNA). An electrical circuit can be modeled as a directed graph whose nodes and branches correspond to the nodes of the circuit and whose branches correspond to the circuit elements like capacitors, resistors and inductors. Using Kirchhoffs laws and the circuit element relations respecting the voltages and the currents, the dynamic of an electrical circuit can be described by a DAE system of the form

$$\mathcal{E}(x) \frac{d}{dt} x = \mathcal{A}x + f(x) + \mathcal{B}u, \quad (1a)$$

$$y = \mathcal{B}^T x, \quad (1b)$$

where

$$x = \begin{bmatrix} \eta^T & i_{\mathcal{L}}^T & i_{\mathcal{V}}^T \end{bmatrix}^T, \quad (1c)$$

$$u = \begin{bmatrix} i_{\mathcal{I}}^T & u_{\mathcal{V}}^T \end{bmatrix}^T, \text{ and} \quad (1d)$$

$$y = - \begin{bmatrix} u_{\mathcal{I}}^T & i_{\mathcal{V}}^T \end{bmatrix}^T \quad (1e)$$

are the vector of states, the vector of inputs and the vector of outputs, respectively, and

$$\mathcal{E}(x) = \begin{bmatrix} A_{\mathcal{L}} \mathcal{C} (A_{\mathcal{C}}^T \eta) A_{\mathcal{C}}^T & 0 & 0 \\ 0 & \mathcal{L}(i_{\mathcal{L}}) & 0 \\ 0 & 0 & 0 \end{bmatrix}, \quad (1f)$$

$$\mathcal{A} = \begin{bmatrix} 0 & -A_{\mathcal{L}} & -A_{\mathcal{V}} \\ A_{\mathcal{L}}^T & 0 & 0 \\ A_{\mathcal{V}}^T & 0 & 0 \end{bmatrix}, \quad (1g)$$

$$f(x) = \begin{bmatrix} -A_{\mathcal{R}} g(A_{\mathcal{R}}^T \eta) \\ 0 \\ 0 \end{bmatrix}, \quad \mathcal{B} = \begin{bmatrix} -A_{\mathcal{I}} & 0 \\ 0 & 0 \\ 0 & -I \end{bmatrix}. \quad (1h)$$

In this model equations,  $\eta$  is the vector of node potentials,  $i_{\mathcal{L}}$ ,  $i_{\mathcal{V}}$  and  $i_{\mathcal{I}}$  are the vectors of currents through inductors, voltage sources and current sources, respectively,  $u_{\mathcal{V}}$  and  $u_{\mathcal{I}}$  are the vectors of voltages of voltage sources and current

A. Steinbrecher is with the Institut für Mathematik, TU Berlin, Straße des 17. Juni 136, D-10623 Berlin, Germany; steinbrecher@math.tu-berlin.de.

sources, respectively. Furthermore,  $A_C \in \mathbb{R}^{n_\eta, n_C}$ ,  $A_L \in \mathbb{R}^{n_\eta, n_L}$ ,  $A_R \in \mathbb{R}^{n_\eta, n_R}$ ,  $A_V \in \mathbb{R}^{n_\eta, n_V}$  and  $A_I \in \mathbb{R}^{n_\eta, n_I}$  are the incidence matrices describing the topology of the corresponding circuit elements, and the conductance matrix-valued function  $\mathcal{C} : \mathbb{R}^{n_C} \rightarrow \mathbb{R}^{n_C, n_C}$ , the inductance matrix-valued function  $\mathcal{L} : \mathbb{R}^{n_L} \rightarrow \mathbb{R}^{n_L, n_L}$  and the resistor relation  $g : \mathbb{R}^{n_R} \rightarrow \mathbb{R}^{n_R}$  characterize the physical properties of the capacitors, inductors and resistors, respectively.

*Assumption 2.1:* We will assume that

- (A1) the matrix  $A_V$  has full column rank,
- (A2) the matrix  $[A_C, A_L, A_R, A_V]$  has full row rank,
- (A3) the matrices  $\mathcal{C}(A_C^T \eta)$  and  $\mathcal{L}(1_L)$  are positive definite for all admissible  $\eta$  and  $1_L$ , and
- (A4) the function  $g(A_R^T \eta)$  is monotonically increasing for all admissible  $\eta$ .

Assumptions (A1) and (A2) imply that the circuit does not contain loops of voltage sources and cutsets of current sources, respectively, while assumptions (A3) and (A4) on the capacitance and inductance matrices and the resistor relation mean that all circuit elements do not generate energy. In the following, we will distinguish between linear and nonlinear circuit elements. A circuit element is called linear if the relation between the current and the voltage along the element is linear. In the case of a nonlinear relation, the circuit element is called nonlinear. We restrict ourselves to circuits that have a small number of nonlinear elements. Furthermore, we assume without loss of generality that the circuit elements are ordered such that

$$A_C = \begin{bmatrix} A_{\bar{C}} & A_{\tilde{C}} \end{bmatrix}, \quad A_L = \begin{bmatrix} A_{\bar{L}} & A_{\tilde{L}} \end{bmatrix}, \quad (1i)$$

$$A_R = \begin{bmatrix} A_{\bar{R}} & A_{\tilde{R}} \end{bmatrix}, \quad (1j)$$

where the incidence matrices  $A_{\bar{C}}$ ,  $A_{\bar{L}}$  and  $A_{\bar{R}}$  correspond to the linear circuit components, and  $A_{\tilde{C}}$ ,  $A_{\tilde{L}}$  and  $A_{\tilde{R}}$  are the incidence matrices for the nonlinear devices. We use the notation, that the bar and the tilde illustrate linear and nonlinear components of the circuit, respectively. We also assume that the linear and nonlinear elements are not mutually connected, i.e.,

$$\mathcal{C}(A_C^T \eta) = \begin{bmatrix} \bar{\mathcal{C}} & 0 \\ 0 & \tilde{\mathcal{C}}(A_{\tilde{C}}^T \eta) \end{bmatrix}, \quad \mathcal{L}(1_L) = \begin{bmatrix} \bar{\mathcal{L}} & 0 \\ 0 & \tilde{\mathcal{L}}(1_{\tilde{L}}) \end{bmatrix}, \quad (1k)$$

$$g(A_R^T \eta) = \begin{bmatrix} \bar{g}(A_{\bar{R}}^T \eta) \\ \tilde{g}(A_{\tilde{R}}^T \eta) \end{bmatrix}, \quad (1l)$$

where  $1_{\tilde{L}}$  is the vector of currents through the nonlinear inductors. It follows from assumptions (A3) and (A4) that the matrices  $\bar{\mathcal{C}} \in \mathbb{R}^{n_{\bar{C}}, n_{\bar{C}}}$ ,  $\bar{\mathcal{L}} \in \mathbb{R}^{n_{\bar{L}}, n_{\bar{L}}}$  and  $\bar{g} \in \mathbb{R}^{n_{\bar{R}}, n_{\bar{R}}}$  for the linear element are symmetric, positive definite, and  $\bar{\mathcal{C}} : \mathbb{R}^{n_{\bar{C}}} \rightarrow \mathbb{R}^{n_{\bar{C}}, n_{\bar{C}}}$  and  $\bar{\mathcal{L}} : \mathbb{R}^{n_{\bar{L}}} \rightarrow \mathbb{R}^{n_{\bar{L}}, n_{\bar{L}}}$  for the capacitors and inductors are positive definite for all admissible  $\eta$  and  $1_{\tilde{L}}$ .

### III. MODEL REDUCTION FOR NONLINEAR CIRCUITS

In the following we present a model reduction technique for the model equations of nonlinear circuits with a small

number of nonlinear elements. This reduction technique bases on the decoupling of the linear and nonlinear subcircuits of the electrical circuit in a suitable way. Afterwards, a model reduction of the remained linear part will be performed using passivity-preserving balanced truncation [6], [7] followed by an adequate recoupling of the unchanged nonlinear subcircuit and the reduced linear subcircuit to obtain a nonlinear reduced-order model, as illustrated in Figure 1.

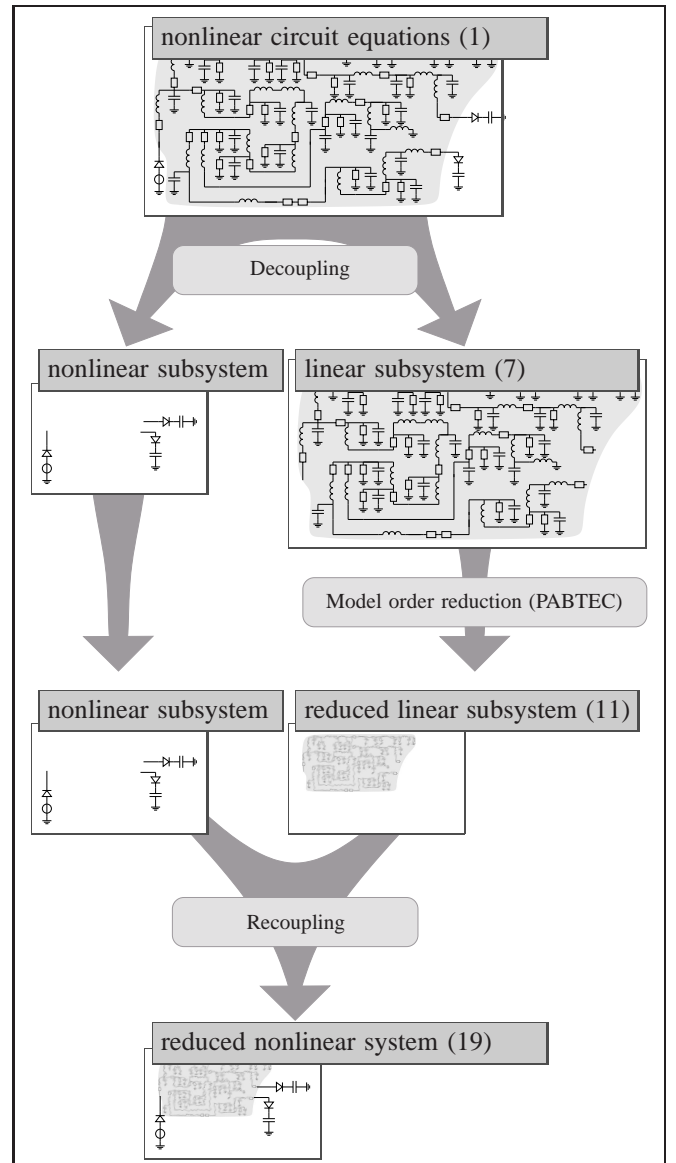

Fig. 1. Model order reduction strategy

#### A. Decoupling of Linear and Nonlinear Subcircuits

In preparation for the decoupling strategy we will introduce the following notation and present the following definition and the following two lemmata.

*Notation 3.1:* Let  $G_1, G_2 \in \mathbb{R}^{n_{\bar{R}}, n_{\bar{R}}}$  be given such that

$(G_1 + G_2)$  is invertible. Then we use

$$\begin{aligned}\Gamma_s &= G_1 + G_2, \\ \Gamma_{11} &= G_1(G_1 + G_2)^{-1}G_1, \\ \Gamma_{12} &= G_1(G_1 + G_2)^{-1}G_2, \\ \Gamma_{21} &= G_2(G_1 + G_2)^{-1}G_1, \\ \Gamma_{22} &= G_2(G_1 + G_2)^{-1}G_2.\end{aligned}$$

*Definition 3.2* (): Let  $A_{\tilde{\mathcal{R}}} \in \{-1, 0, 1\}^{n_\eta, n_{\tilde{\mathcal{R}}}}$  be an incidence matrix. Then the matrices  $A_{\tilde{\mathcal{R}}}^1$  and  $A_{\tilde{\mathcal{R}}}^2$  are uniquely defined with  $A_{\tilde{\mathcal{R}}}^1 \in \{0, 1\}^{n_\eta, n_{\tilde{\mathcal{R}}}}$  and  $A_{\tilde{\mathcal{R}}}^2 \in \{-1, 0\}^{n_\eta, n_{\tilde{\mathcal{R}}}}$  satisfying  $A_{\tilde{\mathcal{R}}}^1 + A_{\tilde{\mathcal{R}}}^2 = A_{\tilde{\mathcal{R}}}$ .

*Lemma 3.3*: Let  $G_1, G_2 \in \mathbb{R}^{n_{\tilde{\mathcal{R}}}, n_{\tilde{\mathcal{R}}}}$  be given such that  $\Gamma_s = (G_1 + G_2)$  is invertible. Then, with Notation 3.1 we get the relations

$$\Gamma_{12} = \Gamma_{21}, \quad (2a)$$

$$\Gamma_{12} = G_1 - \Gamma_{11}, \quad (2b)$$

$$\Gamma_{12} = G_2 - \Gamma_{22}. \quad (2c)$$

*Proof*: We have

$$\begin{aligned}\Gamma_{12} &= G_1(G_1 + G_2)^{-1}(G_2 + G_1 - G_1) \\ &= G_1 - \Gamma_{11} \\ &= G_1 - (G_1 + G_2 - G_2)(G_1 + G_2)^{-1}G_1 \\ &= \Gamma_{21}.\end{aligned}$$

Thus, (2a) and (2b) hold. Relation (2c) can be proved analogously. ■

*Lemma 3.4*: Let  $G_1, G_2 \in \mathbb{R}^{n_{\tilde{\mathcal{R}}}, n_{\tilde{\mathcal{R}}}}$  be given such that  $\Gamma_s = (G_1 + G_2)$  is invertible. Furthermore, let  $A_{\tilde{\mathcal{R}}} \in \{-1, 0, 1\}^{n_\eta, n_{\tilde{\mathcal{R}}}}$  be an incidence matrix. Then, with Notation 3.1 and Definition 3.2 we get the relation

$$\begin{aligned}A_{\tilde{\mathcal{R}}}\Gamma_{12}A_{\tilde{\mathcal{R}}}^T &= \begin{bmatrix} A_{\tilde{\mathcal{R}}}^1 & A_{\tilde{\mathcal{R}}}^2 \end{bmatrix} \begin{bmatrix} G_1 - \Gamma_{11} & \Gamma_{12} \\ \Gamma_{21} & G_2 - \Gamma_{22} \end{bmatrix} \begin{bmatrix} (A_{\tilde{\mathcal{R}}}^1)^T \\ (A_{\tilde{\mathcal{R}}}^2)^T \end{bmatrix}.\end{aligned}$$

*Proof*: For

$$A_{\tilde{\mathcal{R}}} = A_{\tilde{\mathcal{R}}}^1 + A_{\tilde{\mathcal{R}}}^2 = \begin{bmatrix} A_{\tilde{\mathcal{R}}}^1 & A_{\tilde{\mathcal{R}}}^2 \end{bmatrix} \begin{bmatrix} I \\ I \end{bmatrix},$$

we get

$$\begin{aligned}A_{\tilde{\mathcal{R}}}\Gamma_{12}A_{\tilde{\mathcal{R}}}^T &= \begin{bmatrix} A_{\tilde{\mathcal{R}}}^1 & A_{\tilde{\mathcal{R}}}^2 \end{bmatrix} \begin{bmatrix} I \\ I \end{bmatrix} \Gamma_{12} \begin{bmatrix} I & I \end{bmatrix} \begin{bmatrix} (A_{\tilde{\mathcal{R}}}^1)^T \\ (A_{\tilde{\mathcal{R}}}^2)^T \end{bmatrix} \\ &= \begin{bmatrix} A_{\tilde{\mathcal{R}}}^1 & A_{\tilde{\mathcal{R}}}^2 \end{bmatrix} \begin{bmatrix} \Gamma_{12} & \Gamma_{12} \\ \Gamma_{12} & \Gamma_{12} \end{bmatrix} \begin{bmatrix} (A_{\tilde{\mathcal{R}}}^1)^T \\ (A_{\tilde{\mathcal{R}}}^2)^T \end{bmatrix}.\end{aligned}$$

Then the statement follows from Lemma 3.3. ■

The main result of the model order reduction is shown in the following theorem.

*Theorem 3.5*: Consider the circuit equations (1). Let  $A_{\tilde{\mathcal{R}}}^1$  and  $A_{\tilde{\mathcal{R}}}^2$  be defined in Definition 3.2 and let  $G_1, G_2 \in \mathbb{R}^{n_{\tilde{\mathcal{R}}}, n_{\tilde{\mathcal{R}}}}$  be given such that  $G_1$  and  $\Gamma_s = G_1 + G_2$  are

both positive definite and  $G_2$  is positive semidefinite. Furthermore, let  $1_{\tilde{\mathcal{L}}} \in \mathbb{R}^{n_{\tilde{\mathcal{L}}}}$ ,  $u_{\tilde{\mathcal{C}}} \in \mathbb{R}^{n_{\tilde{\mathcal{C}}}}$ , and  $1_z \in \mathbb{R}^{n_{\tilde{\mathcal{R}}}}$  be defined by the relations

$$\tilde{\mathcal{L}}(1_{\tilde{\mathcal{L}}}) \frac{d}{dt} 1_{\tilde{\mathcal{L}}} = A_{\tilde{\mathcal{L}}}^T \eta, \quad (3)$$

$$u_{\tilde{\mathcal{C}}} = A_{\tilde{\mathcal{C}}}^T \eta, \quad (4)$$

$$1_z = \Gamma_s G_1^{-1} (\tilde{g}(A_{\tilde{\mathcal{R}}}^T \eta) - \Gamma_{12} A_{\tilde{\mathcal{R}}}^T \eta). \quad (5)$$

Then system (1) together with the relations

$$\eta_z = \Gamma_s^{-1} ((G_1 (A_{\tilde{\mathcal{R}}}^1)^T - G_2 (A_{\tilde{\mathcal{R}}}^2)^T) \eta - 1_z), \quad (6a)$$

$$1_{\tilde{\mathcal{C}}} = \tilde{\mathcal{C}}(u_{\tilde{\mathcal{C}}}) \frac{d}{dt} u_{\tilde{\mathcal{C}}} \quad (6b)$$

for the additional unknowns  $\eta_z \in \mathbb{R}^{n_{\tilde{\mathcal{R}}}}$  and  $1_{\tilde{\mathcal{C}}} \in \mathbb{R}^{n_{\tilde{\mathcal{C}}}}$ , is equivalent to the system

$$\begin{bmatrix} A_{\tilde{\mathcal{C}}}\tilde{\mathcal{C}}A_{\tilde{\mathcal{C}}}^T & 0 & 0 & 0 & 0 \\ 0 & 0 & 0 & 0 & 0 \\ 0 & 0 & \tilde{\mathcal{L}} & 0 & 0 \\ 0 & 0 & 0 & 0 & 0 \\ 0 & 0 & 0 & 0 & 0 \end{bmatrix} \begin{bmatrix} \frac{d}{dt} \eta \\ \frac{d}{dt} \eta_z \\ \frac{d}{dt} 1_{\tilde{\mathcal{L}}} \\ \frac{d}{dt} 1_{\mathcal{V}} \\ \frac{d}{dt} 1_{\tilde{\mathcal{C}}} \end{bmatrix} \quad (7a)$$

$$\begin{aligned} &= \begin{bmatrix} \mathcal{A}_{11} & \mathcal{A}_{12} & -A_{\tilde{\mathcal{L}}} & -A_{\mathcal{V}} & -A_{\tilde{\mathcal{C}}} \\ \mathcal{A}_{12}^T & -\Gamma_s & 0 & 0 & 0 \\ \mathcal{A}_{\tilde{\mathcal{L}}}^T & 0 & 0 & 0 & 0 \\ \mathcal{A}_{\mathcal{V}}^T & 0 & 0 & 0 & 0 \\ \mathcal{A}_{\tilde{\mathcal{C}}}^T & 0 & 0 & 0 & 0 \end{bmatrix} \begin{bmatrix} \eta \\ \eta_z \\ 1_{\tilde{\mathcal{L}}} \\ 1_{\mathcal{V}} \\ 1_{\tilde{\mathcal{C}}} \end{bmatrix} \\ &+ \begin{bmatrix} -A_{\mathcal{I}} & -A_{\tilde{\mathcal{R}}}^2 & -A_{\tilde{\mathcal{L}}} & 0 & 0 \\ 0 & -I & 0 & 0 & 0 \\ 0 & 0 & 0 & 0 & 0 \\ 0 & 0 & 0 & -I & 0 \\ 0 & 0 & 0 & 0 & -I \end{bmatrix} \begin{bmatrix} 1_{\mathcal{I}} \\ 1_z \\ 1_{\tilde{\mathcal{L}}} \\ u_{\mathcal{V}} \\ u_{\tilde{\mathcal{C}}} \end{bmatrix}, \end{aligned}$$

$$\begin{bmatrix} y_1 \\ y_2 \\ y_3 \\ y_4 \\ y_5 \end{bmatrix} = \begin{bmatrix} -A_{\mathcal{I}}^T & 0 & 0 & 0 & 0 \\ -(A_{\tilde{\mathcal{R}}}^2)^T & -I & 0 & 0 & 0 \\ -A_{\tilde{\mathcal{L}}}^T & 0 & 0 & 0 & 0 \\ 0 & 0 & 0 & -I & 0 \\ 0 & 0 & 0 & 0 & -I \end{bmatrix} \begin{bmatrix} \eta \\ \eta_z \\ 1_{\tilde{\mathcal{L}}} \\ 1_{\mathcal{V}} \\ 1_{\tilde{\mathcal{C}}} \end{bmatrix} \quad (7b)$$

with

$$\mathcal{A}_{11} = -A_{\tilde{\mathcal{R}}}\mathcal{G}A_{\tilde{\mathcal{R}}}^T - A_{\tilde{\mathcal{R}}}^1 G_1 (A_{\tilde{\mathcal{R}}}^1)^T - A_{\tilde{\mathcal{R}}}^2 G_2 (A_{\tilde{\mathcal{R}}}^2)^T, \quad (7c)$$

$$\mathcal{A}_{12} = A_{\tilde{\mathcal{R}}}^1 G_1^T - A_{\tilde{\mathcal{R}}}^2 (G_2)^T \quad (7d)$$

in the sense that if  $[\eta^T \quad [1_{\tilde{\mathcal{L}}}^T \quad 1_{\tilde{\mathcal{C}}}^T] \quad 1_{\mathcal{V}}^T]^T$  solves (1) then  $[\eta^T \quad \eta_z^T \quad 1_{\tilde{\mathcal{L}}}^T \quad 1_{\mathcal{V}}^T \quad 1_{\tilde{\mathcal{C}}}^T]^T$  with (6) solves (7) and, conversely, if  $[\eta^T \quad \eta_z^T \quad 1_{\tilde{\mathcal{L}}}^T \quad 1_{\mathcal{V}}^T \quad 1_{\tilde{\mathcal{C}}}^T]^T$  solves (7) then (6) holds and  $[\eta^T \quad [1_{\tilde{\mathcal{L}}}^T \quad 1_{\tilde{\mathcal{C}}}^T] \quad 1_{\mathcal{V}}^T]^T$  solves (1).

*Proof*: The proof can be found in [9]. ■

In the following we will provide a physical interpretation of the equivalent descriptor system (7). This system models an equivalent circuit which arises from the original circuit by replacing the nonlinear elements by controlled sources. In particular, we replace nonlinear capacitors by controlled voltage sources, nonlinear inductors by controlled current sources and nonlinear resistors by small replacement circuits containing two serial linear resistors and one controlled current source connected parallel to one of the resistors. This

replacements are illustrated in Figure 2 and exemplary in Figure 3.

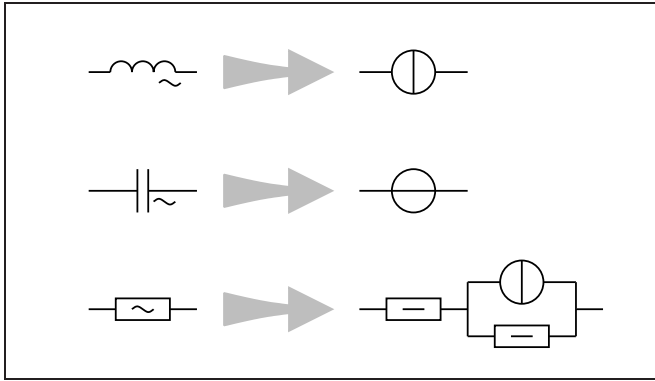

Fig. 2. Replacements

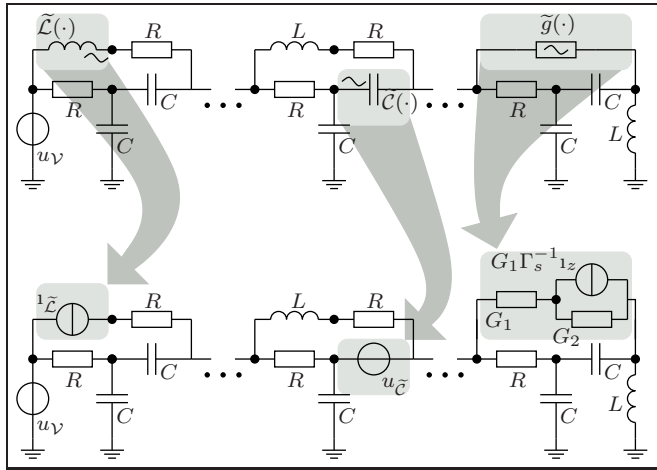

Fig. 3. Exemplary replacements

*Example 3.6:* Consider a simple RCV circuit shown in Figure 4. From the circuit topology we get the incidence

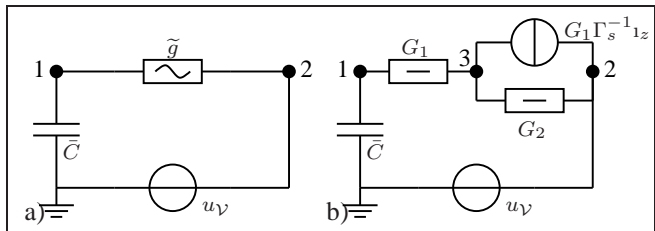

Fig. 4. Simple RCV circuit

matrices

$$\bar{A}_C = \begin{bmatrix} 1 \\ 0 \end{bmatrix}, \quad \tilde{A}_R = \begin{bmatrix} 1 \\ -1 \end{bmatrix}, \quad A_V = \begin{bmatrix} 0 \\ -1 \end{bmatrix},$$

and it follows the nonlinear model equations in the form

$$\begin{bmatrix} \bar{C} & 0 & 0 \\ 0 & 0 & 0 \\ 0 & 0 & 0 \end{bmatrix} \begin{bmatrix} \frac{d}{dt} \eta_1 \\ \frac{d}{dt} \eta_2 \\ \frac{d}{dt} 1_V \end{bmatrix} \quad (8a)$$

$$= \begin{bmatrix} 0 & 0 & 0 \\ 0 & 0 & 1 \\ 0 & -1 & 0 \end{bmatrix} \begin{bmatrix} \eta_1 \\ \eta_2 \\ 1_V \end{bmatrix} + \begin{bmatrix} -g(\eta_1 - \eta_2) \\ g(\eta_1 - \eta_2) \\ 0 \end{bmatrix} + \begin{bmatrix} 0 \\ 0 \\ -1 \end{bmatrix} u_V,$$

$$y = \begin{bmatrix} 0 & 0 & -1 \end{bmatrix} \begin{bmatrix} \eta_1 \\ \eta_2 \\ 1_V \end{bmatrix}. \quad (8b)$$

According the developed strategy, we introduce the new node 3 with the potential  $\eta_3$  and the current source

$$\begin{aligned} 1_z &= \Gamma_s G_1^{-1} (\tilde{g}(A_{\tilde{R}}^T \eta) - \Gamma_{12} A_{\tilde{R}}^T \eta) \\ &= (G_1 + G_2) G_1^{-1} \tilde{g}(\eta_1 - \eta_2) - G_2(\eta_1 - \eta_2) \end{aligned} \quad (9)$$

according (5). We get the equivalent descriptor system in the form

$$\begin{bmatrix} \bar{C} & 0 & 0 & 0 \\ 0 & 0 & 0 & 0 \\ 0 & 0 & 0 & 0 \\ 0 & 0 & 0 & 0 \end{bmatrix} \begin{bmatrix} \frac{d}{dt} \eta_1 \\ \frac{d}{dt} \eta_2 \\ \frac{d}{dt} \eta_3 \\ \frac{d}{dt} 1_V \end{bmatrix} \quad (10a)$$

$$= \begin{bmatrix} -G_1 & 0 & G_1 & 0 \\ 0 & -G_2 & G_2 & 1 \\ G_1 & G_2 & -\Gamma_s & 0 \\ 0 & -1 & 0 & 0 \end{bmatrix} \begin{bmatrix} \eta_1 \\ \eta_2 \\ \eta_3 \\ 1_V \end{bmatrix}$$

$$+ \begin{bmatrix} 0 & 0 \\ 1 & 0 \\ -1 & 0 \\ 0 & -1 \end{bmatrix} \begin{bmatrix} 1_z \\ u_V \end{bmatrix},$$

$$y = \begin{bmatrix} 0 & 1 & -1 & 0 \\ 0 & 0 & 0 & -1 \end{bmatrix} \begin{bmatrix} \eta_1 \\ \eta_2 \\ \eta_3 \\ 1_V \end{bmatrix}. \quad (10b)$$

This system describes the electrical circuit shown in Figure 4b. We now show that systems (8) and (10) are equivalent independently of choice of  $G_1$  and  $G_2$ . From the third equation of (10a) we have

$$\eta_3 = \Gamma_s^{-1} (G_1 \eta_1 + G_2 \eta_2 - 1_z).$$

Substituting it in the first and the second equations in (10a),

we get

$$\begin{aligned} & \begin{bmatrix} \bar{C} & 0 & 0 \\ 0 & 0 & 0 \\ 0 & 0 & 0 \end{bmatrix} \begin{bmatrix} \frac{d}{dt}\eta_1 \\ \frac{d}{dt}\eta_2 \\ \frac{d}{dt}1_\nu \end{bmatrix} \\ &= \begin{bmatrix} -G_1 & 0 & 0 \\ 0 & -G_2 & 1 \\ 0 & -1 & 0 \end{bmatrix} \begin{bmatrix} \eta_1 \\ \eta_2 \\ 1_\nu \end{bmatrix} \\ &+ \begin{bmatrix} 0 & 0 \\ 1 & 0 \\ 0 & -1 \end{bmatrix} \begin{bmatrix} 1_z \\ u_\nu \end{bmatrix} \\ &+ \begin{bmatrix} G_1\Gamma_s^{-1}(G_1\eta_1 + G_2\eta_2 - 1_z) \\ G_2\Gamma_s^{-1}(G_1\eta_1 + G_2\eta_2 - 1_z) \\ 0 \end{bmatrix}. \end{aligned}$$

With (9) it follows

$$\begin{bmatrix} \bar{C} & 0 & 0 \\ 0 & 0 & 0 \\ 0 & 0 & 0 \end{bmatrix} \begin{bmatrix} \frac{d}{dt}\eta_1 \\ \frac{d}{dt}\eta_2 \\ \frac{d}{dt}1_\nu \end{bmatrix} = \begin{bmatrix} -g(\eta_1 - \eta_2) \\ g(\eta_1 - \eta_2) + 1_\nu \\ -\eta_2 - u_\nu \end{bmatrix}$$

which is identical to (8a) independently of the choice of  $G_1$  and  $G_2$ .  $\triangleleft$

### B. Model-Order Reduction of the Linear Subsystem

We now apply the PABTEC method to the linear descriptor system (7). As a result we obtain a reduced-order model

$$\hat{\mathcal{E}} \frac{d}{dt} \hat{x} = \hat{A} \hat{x} + \begin{bmatrix} \hat{B}_1 & \hat{B}_2 & \hat{B}_3 & \hat{B}_4 & \hat{B}_5 \end{bmatrix} \begin{bmatrix} 1_\nu \\ 1_z \\ 1_{\tilde{\mathcal{L}}} \\ u_\nu \\ u_{\tilde{\mathcal{C}}} \end{bmatrix}, \quad (11a)$$

$$\hat{y} = \begin{bmatrix} \hat{C}_1^T & \hat{C}_2^T & \hat{C}_3^T & \hat{C}_4^T & \hat{C}_5^T \end{bmatrix}^T \hat{x}. \quad (11b)$$

For more details in model order reduction of linear circuits and for more details of PABTEC, we refer to [6], [7], [11].

### C. Recoupling of the Reduced Linear Subsystem and the Nonlinear Subsystem

In (11) the vector  $\hat{y}$  is an approximation of the vector of outputs of the equivalent system (7). In particular,  $\hat{y}_j = \hat{C}_j \hat{x}$ ,  $j = 1, \dots, 5$ , approximate the corresponding components of the output in (7b). We have

$$-(A_{\tilde{\mathcal{R}}}^2)^T \eta - \eta_z \approx \hat{C}_2 \hat{x}, \quad (12a)$$

$$-A_{\tilde{\mathcal{L}}}^T \eta \approx \hat{C}_3 \hat{x}, \quad (12b)$$

$$-1_{\tilde{\mathcal{C}}} \approx \hat{C}_5 \hat{x}. \quad (12c)$$

Then the nonlinear equations (3) and (6b) are approximated by

$$\tilde{\mathcal{L}}(\hat{1}_{\tilde{\mathcal{L}}}) \frac{d}{dt} \hat{1}_{\tilde{\mathcal{L}}} = -\hat{C}_3 \hat{x} \quad (13)$$

and

$$\tilde{\mathcal{C}}(\hat{u}_{\tilde{\mathcal{C}}}) \frac{d}{dt} \hat{u}_{\tilde{\mathcal{C}}} = -\hat{C}_5 \hat{x}, \quad (14)$$

respectively, where consequently  $\hat{1}_{\tilde{\mathcal{L}}}$  and  $\hat{u}_{\tilde{\mathcal{C}}}$  now are approximations for  $1_{\tilde{\mathcal{L}}}$  and  $u_{\tilde{\mathcal{C}}}$ , respectively. Furthermore, with  $\eta_z$  defined in (6a) and  $1_z$  defined in (5), we have

$$-(A_{\tilde{\mathcal{R}}}^2)^T \eta - \eta_z = -A_{\tilde{\mathcal{R}}}^T \eta + G_1^{-1} \tilde{g}(A_{\tilde{\mathcal{R}}}^T \eta). \quad (15)$$

Introducing the vector

$$u_{\tilde{\mathcal{R}}} = A_{\tilde{\mathcal{R}}}^T \eta \in \mathbb{R}^{n_{\tilde{\mathcal{R}}}}, \quad (16)$$

then for  $u_{\tilde{\mathcal{R}}}$  we get from (12a) and (15) the relation

$$0 = -G_1 \hat{C}_2 \hat{x} - G_1 \hat{u}_{\tilde{\mathcal{R}}} + \tilde{g}(\hat{u}_{\tilde{\mathcal{R}}}), \quad (17)$$

where now  $\hat{u}_{\tilde{\mathcal{R}}}$  approximates  $u_{\tilde{\mathcal{R}}}$ . Furthermore, from (5) we get with (16)

$$1_z = \Gamma_s G_1^{-1} \tilde{g}(u_{\tilde{\mathcal{R}}}) - G_2 u_{\tilde{\mathcal{R}}}. \quad (18)$$

Now, adding (13), (14), and (17) to (11) and using in addition to  $\hat{x}$  also the approximations  $\hat{1}_{\tilde{\mathcal{L}}}$ ,  $\hat{u}_{\tilde{\mathcal{C}}}$ , and  $\hat{u}_{\tilde{\mathcal{R}}}$  as state variables, then we get with (18) the descriptor system

$$\begin{aligned} & \begin{bmatrix} \hat{\mathcal{E}} & 0 & 0 & 0 \\ 0 & \tilde{\mathcal{L}}(\hat{1}_{\tilde{\mathcal{L}}}) & 0 & 0 \\ 0 & 0 & \tilde{\mathcal{C}}(\hat{u}_{\tilde{\mathcal{C}}}) & 0 \\ 0 & 0 & 0 & 0 \end{bmatrix} \begin{bmatrix} \frac{d}{dt} \hat{x} \\ \frac{d}{dt} \hat{1}_{\tilde{\mathcal{L}}} \\ \frac{d}{dt} \hat{u}_{\tilde{\mathcal{C}}} \\ \frac{d}{dt} \hat{u}_{\tilde{\mathcal{R}}} \end{bmatrix} \\ &= \begin{bmatrix} \hat{A} & \hat{B}_3 & \hat{B}_5 & -\hat{B}_2 G_2 \\ -\hat{C}_3 & 0 & 0 & 0 \\ -\hat{C}_5 & 0 & 0 & 0 \\ -G_1 \hat{C}_2 & 0 & 0 & -G_1 \end{bmatrix} \begin{bmatrix} \hat{x} \\ \hat{1}_{\tilde{\mathcal{L}}} \\ \hat{u}_{\tilde{\mathcal{C}}} \\ \hat{u}_{\tilde{\mathcal{R}}} \end{bmatrix} \\ &+ \begin{bmatrix} \hat{B}_1 & \hat{B}_4 \\ 0 & 0 \\ 0 & 0 \\ 0 & 0 \end{bmatrix} \begin{bmatrix} 1_\nu \\ u_\nu \end{bmatrix} + \begin{bmatrix} \hat{B}_2 \Gamma_s G_1^{-1} \tilde{g}(\hat{u}_{\tilde{\mathcal{R}}}) \\ 0 \\ 0 \\ \tilde{g}(\hat{u}_{\tilde{\mathcal{R}}}) \end{bmatrix}. \end{aligned}$$

Multiplying this system from the left with

$$\begin{bmatrix} I & 0 & 0 & -\hat{B}_2 \Gamma_s G_1^{-1} \\ 0 & I & 0 & 0 \\ 0 & 0 & I & 0 \\ 0 & 0 & 0 & I \end{bmatrix},$$

we obtain, finally, the nonlinear descriptor system

$$\begin{bmatrix} \hat{\mathcal{E}} & 0 & 0 & 0 \\ 0 & \tilde{\mathcal{L}}(\hat{1}_{\tilde{\mathcal{L}}}) & 0 & 0 \\ 0 & 0 & \tilde{\mathcal{C}}(\hat{u}_{\tilde{\mathcal{C}}}) & 0 \\ 0 & 0 & 0 & 0 \end{bmatrix} \begin{bmatrix} \frac{d}{dt} \hat{x} \\ \frac{d}{dt} \hat{1}_{\tilde{\mathcal{L}}} \\ \frac{d}{dt} \hat{u}_{\tilde{\mathcal{C}}} \\ \frac{d}{dt} \hat{u}_{\tilde{\mathcal{R}}} \end{bmatrix} \quad (19a)$$

$$= \begin{bmatrix} \hat{A} + \hat{B}_2 \Gamma_s \hat{C}_2 & \hat{B}_3 & \hat{B}_5 & \hat{B}_2 G_1 \\ -\hat{C}_3 & 0 & 0 & 0 \\ -\hat{C}_5 & 0 & 0 & 0 \\ -G_1 \hat{C}_2 & 0 & 0 & -G_1 \end{bmatrix} \begin{bmatrix} \hat{x} \\ \hat{1}_{\tilde{\mathcal{L}}} \\ \hat{u}_{\tilde{\mathcal{C}}} \\ \hat{u}_{\tilde{\mathcal{R}}} \end{bmatrix}$$

$$+ \begin{bmatrix} \hat{B}_1 & \hat{B}_4 \\ 0 & 0 \\ 0 & 0 \\ 0 & 0 \end{bmatrix} \begin{bmatrix} 1_\nu \\ u_\nu \end{bmatrix} + \begin{bmatrix} 0 \\ 0 \\ 0 \\ \tilde{g}(\hat{u}_{\tilde{\mathcal{R}}}) \end{bmatrix},$$

$$\begin{bmatrix} \hat{y}_1 \\ \hat{y}_4 \end{bmatrix} = \begin{bmatrix} \hat{C}_1 \\ \hat{C}_4 \end{bmatrix} \hat{x} \quad (19b)$$

that approximate the original nonlinear system (1). Consequently the descriptor system (19) can be treated as model order reduction of the original descriptor system (1) and, therefore, (19) can be used for further investigations, in particular, the simulation of the dynamic of the circuit, as illustrated in the next section.

IV. NUMERICAL EXPERIMENTS

In the following we consider the electrical circuit shown in Figure 5. This circuit contains 1000 repetitions of subcircuits containing one inductor, two capacities, and two resistors, as illustrated in Figure 5. Furthermore, at the beginning of the repetitions we have a voltage source with  $u_V = \sin^{10}(100\pi t)$ , see Figure 6, and at the end we have an additional inductor. Beginning with the first repetition every 100 repetitions a linear resistor is replaced by a diode and beginning with the 100th repetition every 100 repetitions a linear inductor is replaced by a nonlinear inductor. For more details we refer to [9].

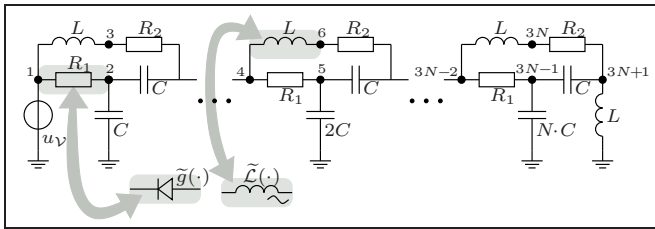

Fig. 5. Electrical circuit

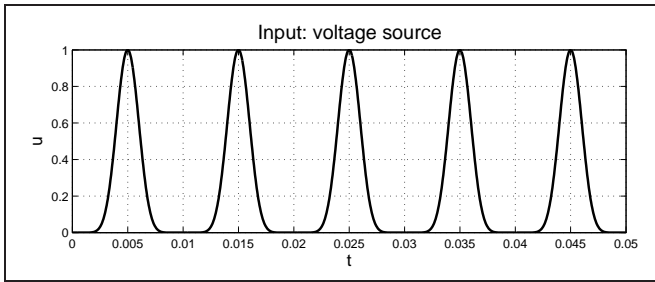

Fig. 6. Voltage source

All together the circuit consists 3001 nodes, 1 voltage source, 1990 linear resistors and 10 diodes, 991 linear inductors and 10 nonlinear inductors, 2000 linear capacities, and 1 output. The state dimension of the model equations is  $n = 4003$ . The numerical simulation of the dynamic is done for  $t \in [0, 0.05]$  seconds using BDF method of order 2 with fixed stepsize of length  $5 \cdot 10^{-5}$ . The computations are done with MATLAB.

For comparison of the efficiency we prescribed several tolerances  $tol \in \{10^{-3}, 10^{-5}, 10^{-7}, 10^{-9}\}$  for the model order reduction of the linear subcircuit using PABTEC. The numerical results for this prescribed tolerances are illustrated in Figures 7-10, respectively. In the upper plot of each figure the solution of the output  $y_1 = -i_V$  of the original system and the output  $\hat{y}_1 = -\hat{i}_V$  of the reduced system is illustrate. Furthermore, in the lower plot, the error between these both solutions are shown.

In Figure 11 the efficiency of the proposed method is illustrated. In Figure 11a) the system dimension of the reduced system in comparison to the prescribed tolerance is depicted. As one can see, if the prescribed tolerance becomes more precise the dimension of the reduced system increases while the obtained error decreases as shown in Figure 11b).

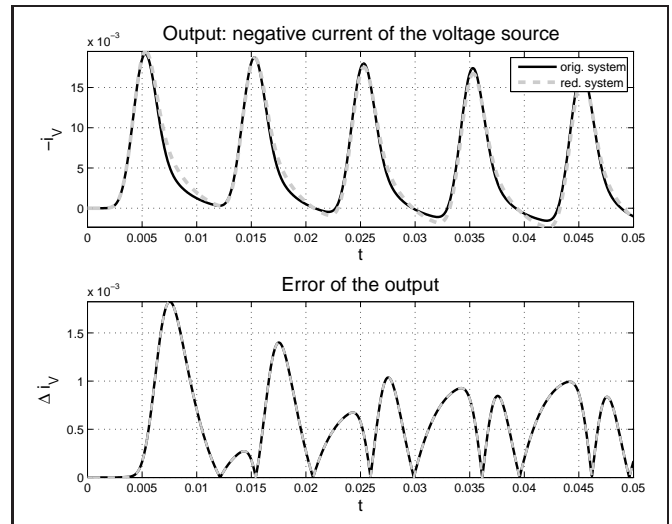

Fig. 7. Solution with prescribed tolerance  $10^{-3}$

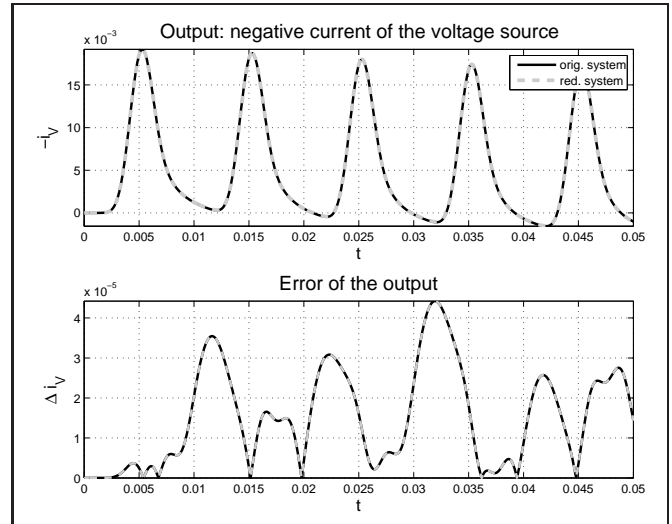

Fig. 8. Solution with prescribed tolerance  $10^{-5}$

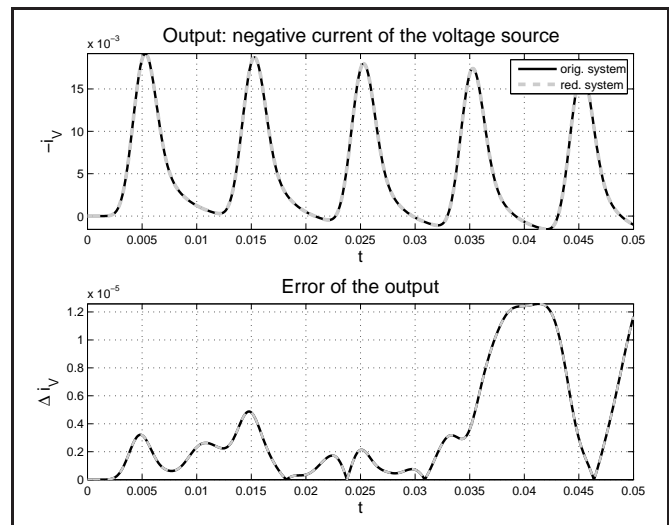

Fig. 9. Solution with prescribed tolerance  $10^{-7}$

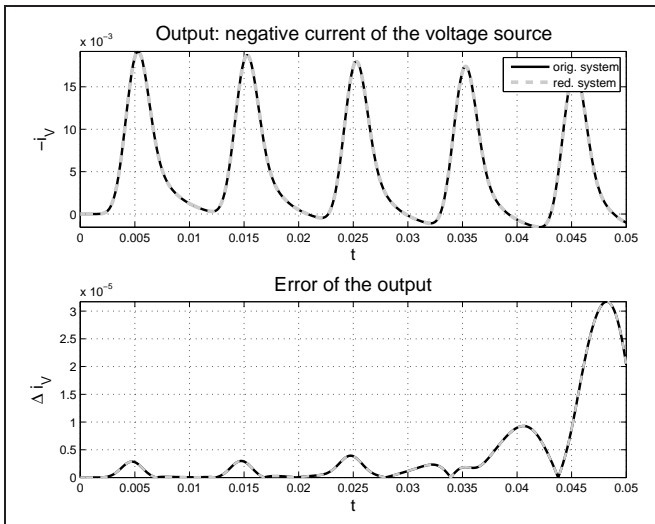
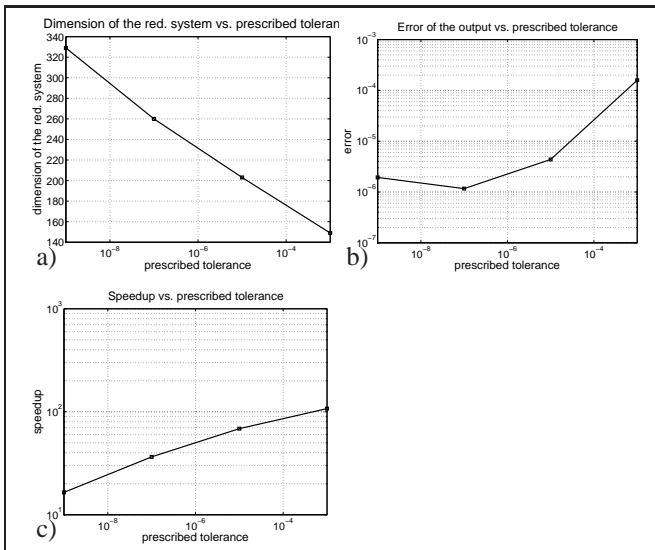

 Fig. 10. Solution with prescribed tolerance  $10^{-9}$ 

Fig. 11. Efficiency

Here, in Figure 11b), the obtained error of the solution of the reduced system with respect to the prescribed tolerance is depicted. Furthermore, in Figure 11c) the speedup for the simulation of the reduced system in comparison to the prescribed tolerance is shown. Obvious, the speedup of the simulation of the reduced system becomes better if the prescribed tolerance becomes larger. See also Table I.

## V. SUMMARY

We developed a model order reduction approach for the model equations of nonlinear circuits with a small number of nonlinear elements, where the model equations form a DAE system obtained by use of the Modified Nodal Analysis. The developed model reduction technique bases on the decoupling of linear and nonlinear subcircuits of the electrical circuit, followed by a model reduction of the remained linear part. Afterwards, the reduced linear subcircuit is recoupled with the unchanged nonlinear subcircuit to

dimension of the original system	4003	4003	4003	4003
simulation time for the original system	4557s	4557s	4557s	4557s
prescribed tolerance for the model reduction	1e-03	1e-05	1e-07	1e-09
time for the model reduction	902s	822s	834s	900s
dimension of the reduced system	149	203	260	329
simulation time for the reduced system	43s	67s	125s	277s
obtained error of the output of the red. system	1.6e-04	4.4e-06	1.16e-06	1.9e-06
speedup	107.2	68.5	36.5	16.5

 TABLE I  
EFFICIENCY

obtain the nonlinear reduced-order model. Furthermore, the efficiency and applicability of the proposed model reduction approach was demonstrated on a numerical example.

## REFERENCES

- [1] R.W. Freund. SPRIM: structure-preserving reduced-order interconnect macromodeling. In *Technical Digest of the 2004 IEEE/ACM International Conference on Computer-Aided Design*, pages 80–87, Los Alamos, CA, 2004.
- [2] R.W. Freund. Structure-preserving model order reduction of RCL circuit equations. In W.H.A. Schilders, H.A. van der Vorst, and J. Rommes, editors, *Model Order Reduction: Theory, Research Aspects and Applications*, volume 13 of *Mathematics in Industry*, pages 49–73. Springer-Verlag, Berlin, Heidelberg, 2008.
- [3] M. Heinkenschloss and T. Reis. Model order reduction for a class of nonlinear electrical circuits. In *Proceedings of the 48th IEEE Conference on Decision and Control (CDC 2009, Shanghai, China, December 16-18, 2009)*. IEEE, 2009.
- [4] A. Odabasioglu, M. Celik, and L.T. Pileggi. PRIMA: Passive reduced-order interconnect macromodeling algorithm. *IEEE Trans. Circuits Syst.*, 17(8):645–654, 1998.
- [5] J. R. Phillips. Projection-based approaches for model reduction of weakly nonlinear, time-varying systems. *IEEE Trans. Computer-Aided Design Integr. Circuits Syst.*, 22(2):171–187, 2003.
- [6] T. Reis and T. Stykel. Passivity-preserving balanced truncation for electrical circuits. Preprint 2008/32, Institut für Mathematik, Technische Universität Berlin, Straße des 17. Juni 136, 10623 Berlin, Germany, 2008. Submitted for publication in *IEEE Trans. Circuits Syst.*
- [7] T. Reis and T. Stykel. Positive real and bounded real balancing for model reduction of descriptor systems. *Internat. J. Control*, 83(1):74–88, 2009.
- [8] M.J. Rewieński. *A Trajectory Piecewise-Linear Approach to Model Order Reduction of Nonlinear Dynamical Systems*. Ph.D. thesis, Massachusetts Institute of Technology, 2003.
- [9] A. Steinbrecher and T. Stykel. Model order reduction of nonlinear circuits with a small number of nonlinear elements. Technical report, Institut für Mathematik, Technische Universität Berlin, Berlin, Germany, in preparation.
- [10] M. Striebel and J. Rommes. Model order reduction of nonlinear systems: status, open issues, and applications. Preprint 08-07, Technische Universität Chemnitz, 2008.
- [11] T. Stykel. *Analysis and Numerical Solution of Generalized Lyapunov Equations*. PhD thesis, Institut für Mathematik, Technische Universität Berlin, Berlin, Germany, June 2002.
- [12] A. Verhoeven, J. ter Maten, M. Striebel, and R. Mattheij. Model order reduction for nonlinear IC models. In *System Modeling and Optimization*, IFIP Advances in Information and Communication Technology, Vol. 312/2009, pages 476–491. Springer, 2009.